

First test of a BAE transducing scheme on a Resonant Gravitational-Wave Antenna^(*)

P. BONIFAZI, S. VASELLI and M. VISCO

Istituto di Fisica dello Spazio Interplanetario del CNR - Frascati, Italy

(ricevuto il 5 Dicembre 1996; approvato il 25 Febbraio 1997)

Summary. — We present the results obtained with a resonant capacitive transducer, suitable for Back Action Evasion (BAE) measurements, coupled for the first time to a gravitational-wave antenna. This scheme was developed in collaboration with the Group of the University of Rome La Sapienza. The antenna is a 270 kg aluminum 5056 alloy cylinder, with a resonant frequency of 1805 Hz, operating at 4.2 K in the ALTAIR cryostat, located in Frascati (Italy) at the IFSI-CNR laboratory. The apparatus was able to work continuously for periods as long as days, both in up-conversion and BAE configurations, with good stability. The behaviour of the system is in reasonable agreement with a proposed model of a double harmonic oscillator in a BAE readout scheme. The limits on the sensitivity of this set-up are discussed as well as the possible future improvements.

PACS 04.80 – Experimental studies of gravity.

PACS 95.85 – Astronomical observations.

PACS 01.30.Cc – Conference proceedings.

1. – Introduction

A resonant gravitational antenna absorbs only a very small amount of the energy carried by a gravitational wave passing through it, therefore ultra-sensitive displacement transducers are needed to measure the corresponding weak excitation of the antenna normal modes. Linear transducers, commonly used [1-3], are reciprocal devices. As a result, the amplifier noise produces on the antenna a random displacement, called back action noise, that cannot be distinguished from the thermal motion. The use of a back-action-evading transducer has been proposed to avoid this problem and to improve the sensitivity of resonant gravitational antennae [4]. In this paper we describe the results obtained with a so-called *parametric bridge transducer* coupled, for the first time, to a gravitational-wave antenna. The parametric transducer concept has been explored and

(*) Paper presented at the VII Cosmic Physics National Conference, Rimini, October 26-28, 1994.

actively developed by several groups [5-7]. In all parametric transducers an oscillating electromagnetic source *pump*, usually in radio-frequency or microwave band, excites an electrical circuit, a reactive parameter of which is modulated by the motion of a resonant proof mass mechanically coupled to the antenna. This process generates sidebands on the source signal at the sum and difference of the source frequency and the proof mass resonant frequency. A model, based on a push-pull transducer, has been developed in collaboration with the group of the Rome University [8,9], and tested using the experimental set-up here described. In a BAE scheme of transduction the energy transfer from the mechanical to the electrical part depends on the signal phase. Only one phase of the electrical noise produces the back action and only one phase of the mechanical motion is reported at the output and peculiarly this is back action free.

The experimental apparatus consists in an antenna, in an electromechanical resonant capacitive transducer, well tuned to the first longitudinal mode of the bar, and in a read-out electric LC circuit, resonating at a frequency ν_e much higher than the mechanical one. The antenna-transducer system can be modeled as two coupled harmonic oscillators. The two resulting modes have frequencies ν_- and ν_+ , splitted by a quantity that depends on the ratio μ between the equivalent masses of the two uncoupled oscillators. The capacitive transducer is biased by an electric field $E(t)$ which couples the two mechanical modes to the electric LC oscillator.

$$(1) \quad E(t) = \frac{E_-}{2} \{ (1 + f_-) \cos[(\omega_e - \omega_-)t + \pi] + (1 - f_-) \cos[(\omega_e + \omega_-)t + \pi] \} + \frac{E_+}{2} \{ (1 + f_+) \cos[(\omega_e - \omega_+)t] + (1 - f_+) \cos[(\omega_e + \omega_+)t] \},$$

where f_{\pm} can assume the values $-1, 0, 1$ and $E_{\pm} = 0, V_{\pm}/d$. V_{\pm} is the amplitude of the dynamical electrical coupling field (*pump*), and d is the gap of the capacitive transducer. The values 1 and -1 correspond, respectively, to the up and down parametric conversion of the mechanical signal. When f_- (and/or f_+) is zero, the mode ν_- (and/or ν_+) is monitored in a BAE configuration. It is possible to show [8] that the basic BAE behaviour of the whole system can be analysed using the complex amplitudes of the three oscillators Ξ_{-i} , Ξ_{+i} , and Q_i , the two mechanical and the electric one, with $i = 1, 2$:

$$(2) \quad \begin{cases} \Xi_{-2} + j\Xi_{-1} = \frac{1}{\omega_-} (\dot{\xi}_- + j\omega_- \xi_-) e^{-j\omega_- t}, \\ \Xi_{+2} + j\Xi_{+1} = \frac{1}{\omega_+} (\dot{\xi}_+ + j\omega_+ \xi_+) e^{-j\omega_+ t}, \\ Q_2 + jQ_1 = \frac{1}{\omega_e} (\dot{q} + j\omega_e q) e^{-j\omega_e t}, \end{cases}$$

where q is the charge variation on the transducer plates, and ξ_- , ξ_+ are the two reduced normal coordinates.

From the analysis of the system in terms of these new coordinates, because of the particular time dependence of the electric bias field in BAE configuration, it follows that the two components Ξ_{+2} and Ξ_{-2} do not contribute to the time evolution of the output. On the other hand, the other two coordinates Ξ_{+1} and Ξ_{-1} affect only the component Q_2 of the output signal (*forward correlation*). Therefore Q_2 carries the information of the interaction of any external classical force $F(t)$ applied on the antenna, able to excite the Ξ_{+1} and Ξ_{-1} coordinates. It is possible to show that the electric noise of the amplifier spoils both the components Q_1 and Q_2 of the electric oscillator. Only Q_1 influences the time evolution

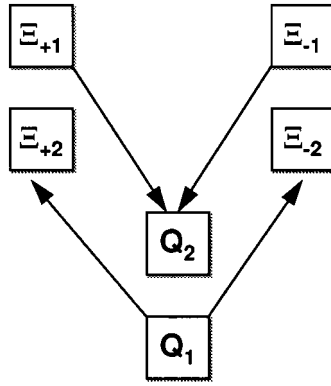

Fig. 1. – Sketch of the relations between the six complex amplitude components in a BAE scheme of measurement.

of the mechanical part of the circuit and, more precisely, the two components Ξ_{+2} and Ξ_{-2} (*back correlation*). This means that any back action effect is avoided. In fig. 1 a sketch of the relations between these six amplitude components is shown.

The possibility of using a parametric transducer as a BAE system gives great advantages over other linear transduction schemes such as the inductive or capacitive transducer, although at the cost of increased complexity. In fact, as we have shortly explained, the noise of the amplifier used to sense the transducer circuit may be kept from acting back on the mechanical proof mass. This, in effect, isolates the antenna from the back acting part of the transducer noise and improves the overall antenna sensitivity. One of the drawbacks of the parametric transducer arises from the phase and amplitude fluctuations of the *pump* sources. The solution to this problem is to employ a balanced bridge circuit in which the *pump* signal, and its noise, is cancelled to a large extent at the transducer output.

2. – Experimental apparatus and results

The circuit we used for the measurements is reported in fig. 2. In our experimental apparatus the mechanical oscillator is the central electrode of a differential capacitive transducer that is inserted in a well-balanced bridge, in this way the white noise of the *pump* oscillators does not produce a random displacement of the antenna and it is not directly reported to the output.

Two superconducting transformers were present in the circuit, the first one at the *pump* outputs (with ratio 1 : 9 and $k = 0.7$) was used to increase the electric field in the transducer, the second one (with ratio 12 : 1 and $k = 0.7$) provides the required electrical matching between the output circuit and a commercial PAR 113 amplifier.

The parameters that have a great influence on the overall sensitivity are the quality factor Q_e of the electrical circuit, the balancing η of the bridge, the electrical noise of the *pump* generators and the mechanical quality factors of the two modes.

The η factor can be expressed, *vs.* ω , as follows:

$$(3) \quad \eta(\omega) = \frac{\omega C}{4} \sqrt{(\Delta R)^2 + \left(\frac{\Delta C}{C}\right)^2 \frac{1}{\omega^2 C^2}},$$

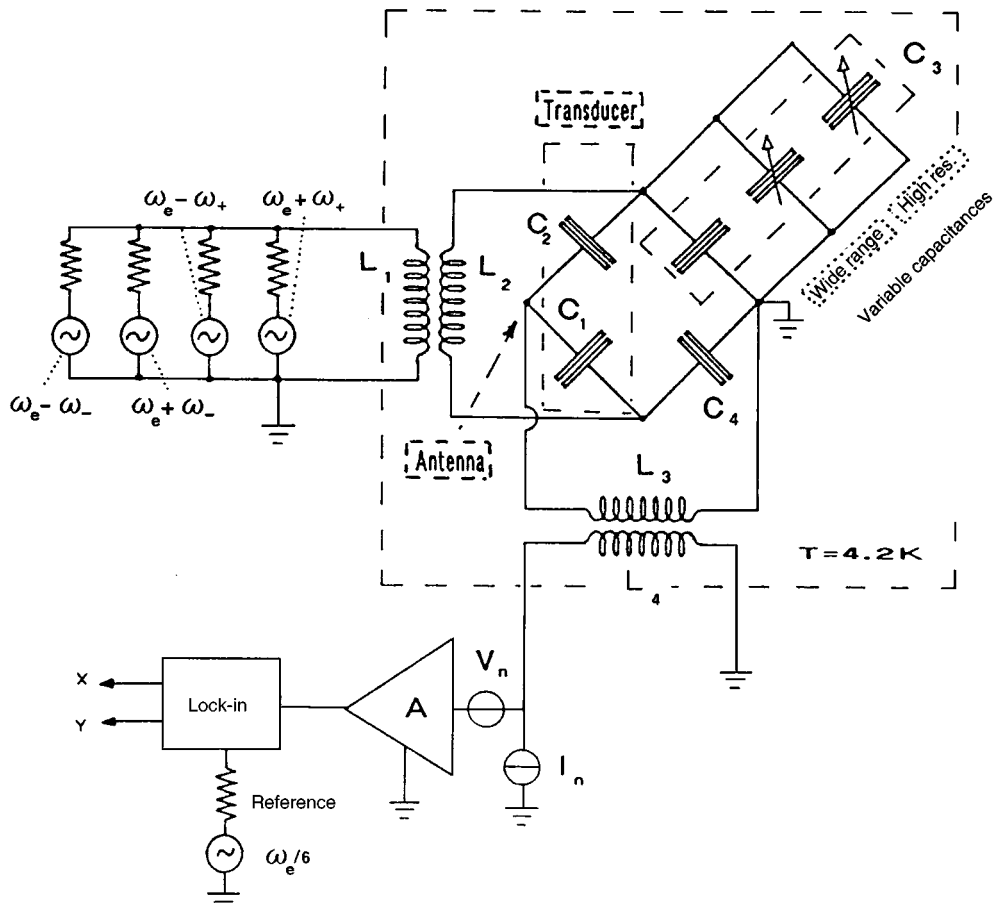

Fig. 2. - Scheme of the complete transducing configuration.

where ΔR and ΔC are, respectively, the resistive and capacitive unbalance of the bridge, with $\omega_e RC \ll 1$, $\Delta R/R < 1$ and $\Delta C/C \ll 1$. The transducer used has a reduced mass of 76 g, resonating at a frequency close, within 1 Hz, to the first longitudinal mode of the antenna. The two capacitances of the transducer (about 800 pF each) are inserted in a bridge, resonating at 210.5 kHz with a Q_e of 24000, that can be carefully balanced in the range of 10 ppm, by means of two variable capacitances. The frequencies of the two normal modes and their mechanical quality factors at 4.2 K are, respectively, $\nu_- = 1783.863$ Hz ($Q_- = 2.86 \times 10^6$) and $\nu_+ = 1827.102$ Hz ($Q_+ = 2.98 \times 10^6$).

The value of the bridge balancing $\eta = 2 \times 10^{-4}$ is worst than that (8×10^{-7}) previously obtained, in the laboratory [10]. This is probably due to resistive elements present in the bridge. We suspect the oxidation of one sliding contact of a variable capacitor (0–120 pF) of the bridge.

A preliminary test on the scheme was made working in up-conversion configuration. Theoretical calculations show that if the electric field in the transducer is not too high, *i.e.* the coupling between the mechanical and the electrical part of the circuit is not too strong, the transduction coefficient α is the same working in BAE or in up-conversion pumping.

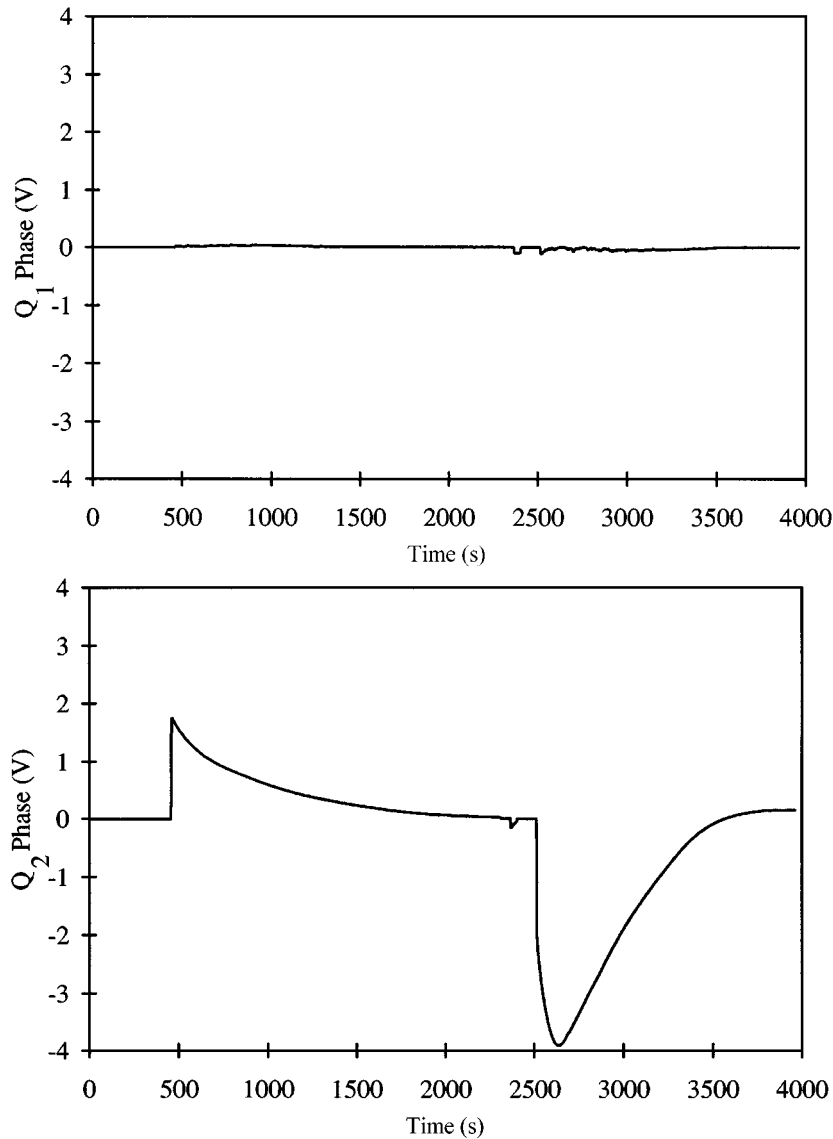

Fig. 3. – Plot *vs.* time of the two outputs of the lock-in, with the mechanical modes excited well above the noise level, in BAE configuration.

From the experimental data we computed the following values of the transduction coefficients $\alpha_- = (8.7 \pm 0.3) \times 10^7$ and $\alpha_+ = (6.7 \pm 0.2) \times 10^7$, that are in fair agreement with the theoretical value of 15×10^7 (V/m), calculated using the model, with a *pump* amplitude of $5 V_{pp}$ [11].

We performed several runs in the BAE configuration. During our measurement runs we have recorded about 30 days of data, in different experimental conditions. We biased the transducer using four commercial synthesizers HP 3325 (with $A_p = 5 V_{pp}$) and phase

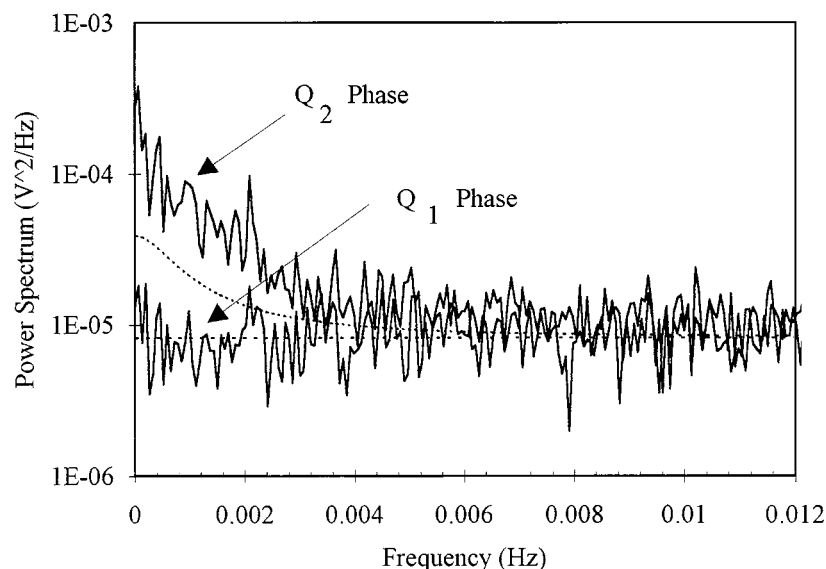

Fig. 4. – Plot of the spectra of the two phases of the lock-in for 7 hours of data, starting from 2 UT of January, 1994. On the Q_2 phase, a peak is present with bandwidth and amplitude in agreement with the theoretical predictions (see the continuous curves).

noise level of $-100 \text{ dBc}/(\text{Hz})^{1/2}$ (decibels below the carrier, at 1 kHz from it). The output of the electric circuit is demodulated at a ν_e frequency by a lock-in, whose two output phases Q_1 and Q_2 are acquired.

We show in fig. 3 the plots, *vs.* time, of the amplitudes of these two electric phases after having excited, by a piezoelectric ceramic glued on the antenna, the two mechanical modes well above the noise level. As predicted by the theory, the signal produced by the excitation of the mechanical system at each of the two modes is present only on one of the two output phases. We stress that the phase of the exciting pulses applied to the PZ ceramics was arbitrary and therefore it is not correlated with the phase of the synthesizer used as *pump* oscillators.

In fig. 4 we show, as an example, the plot of the power spectra of the two phases relative to a period of 7 hours of data (starting on 02:00 UT of January 12, 1994), sampled at 1 s. As one can easily notice, most of the signal appears only on one of the two phases. At zero frequency we have the superposition of the signals coming from the two modes of oscillation. The frequencies of the *pump* oscillators were well tuned, so that both the signals are reported within one millihertz to zero frequency.

The amplitudes are compatible with the theoretical ones. The agreement is good but, unfortunately, we could not verify the absence of the back action, due to the poor balancing of the bridge. In fact, the output was dominated by the noise produced by the *pump* oscillators and the equivalent temperatures of the two modes were higher than the thermodynamic one (5.2 K).

In conclusion, we concentrated our efforts in testing the basic theory of this transduction scheme applied, for the first time, to a gravitational-wave antenna. In the near future it would be possible to bring the sensitivity of the experiment to an effective noise temperature of a few mK, by balancing the bridge at 10^{-6} , by improving an order of magnitude

the noise of the *pump* oscillators, and by using a very low-noise FET amplifier.

* * *

We would like to thank G. MARTINELLI and F. TABACCHIONI for their valuable technical support and the *Research Area* of CNR, in Frascati, for the very efficient supply of cryogenic liquids. We are indebted to our colleagues of the Rome resonant bar group for the continued support.

REFERENCES

- [1] ASTONE P., BASSAN M., BONIFAZI P., CARELLI P., CASTELLANO M. G., CAVALLARI G., COCCIA E., COSMELLI C., FAFONE V., FRASCA S., MAJORANA E., MODENA I., PALLOTTINO G. V., PIZZELLA G., RAPAGNANI P., RICCI F. and VISCO M., *Phys. Rev. D*, **47** (1993) 362.
- [2] BONIFAZI P. and VISCO M., *Nuovo Cimento C*, **15** (1992) 943.
- [3] SOLOMONSON N., HAMILTON W. O., JOHNSON W. and XU B., *Rev. Sci. Instrum.*, **65** (1994) 174.
- [4] CAVES C. M., THORNE K. S., DREVER R. W. P., SANDBERG V. D. and ZIMMERMAN M., *Rev. Mod. Phys.*, **52** (1980) 341.
- [5] BOCKO M. F., NARICI L., DOUGLASS D. H. and JOHNSON W. W., *Phys. Lett. A*, **97** (1983) 259.
- [6] SPETZ G. W., MANN A. G., HAMILTON W. O. and OELFKE W. C., *Phys. Lett. A*, **104** (1984) 335.
- [7] AGUIAR O. D., JOHNSON W. W. and HAMILTON W. O., *Rev. Sci. Instrum.*, **62** (1991) 11; 2523.
- [8] PUPPO P., Thesis (unpublished), University of Rome La Sapienza (1993).
- [9] CINQUEGRANA C., MAJORANA E., RAPAGNANI P. and RICCI F., *Phys. Rev. D*, **48** (1993) 448.
- [10] MAJORANA E., PERGOLA N., PUPPO P., RAPAGNANI P. and RICCI F., *Phys. Lett. A*, **180** (1993) 43.
- [11] BONIFAZI P., CINQUEGRANA C., MAJORANA E., PERGOLA P., PUPPO P., RAPAGNANI P., RICCI F., VANNARONI G. and VISCO M., *First Amaldi Conference on Gravitational Wave Experiments* (World Scientific, Singapore) 1995, pp. 368-379.