

Image acquisition system for the Italian panoramic monochromator of the THEMIS telescope^(*)^(**)

F. BERRILLI, B. CACCIN, S. CANTARANO and A. EGIDI

Dipartimento di Fisica, Università di Roma II "Tor Vergata" - Roma, Italy

(ricevuto il 4 Aprile 1996; approvato il 24 Maggio 1996)

Summary. — We describe the image acquisition system of the Italian panoramic monochromator which will be in operation at the focus F_2 of the THEMIS solar telescope to acquire images of the Sun in the visible spectrum (between 420 and 700 nm) with a spectral resolving power of about 300 000. The system consists of two CCD cameras (using either 512×512 or 1024×1024 square-pixel sensors) controlled and read-out by dedicated electronics and a personal computer. The data transmission between the sensors and the computer is performed by means of an optical link.

PACS 96.60 – Solar physics.

PACS 95.55.Ev – Solar instruments.

PACS 01.30.Cc – Conference proceedings.

1. – The IPM project

The THEMIS telescope is a “polarization-free” telescope designed to obtain accurate measurements of the vector magnetic field and high-quality images of the solar surface [1]. This instrument allows different observing modes in imagery, while the spectrographs permit mono- and bi-dimensional spectroscopy.

The Italian Panoramic Monochromator (IPM) has been designed to obtain images of the solar atmosphere between 420 and 700 nm [2, 3]. The Arcetri staff took care of the optical design and test of the IPM, including the electronic control of the spectroscopic apparatus, while the image acquisition system (IMACS), described in this paper, has been developed at the Physics Department of Tor Vergata University.

The IPM basically consists of a feed-back controlled Fabry-Perot interferometer, mounted after a Zeiss Universal Birefringent Filter (UBF) used as order sorter. The bandpass in wavelength is an Airy function with a full width at half-maximum of 210 pm at

(*) Paper presented at the VII Cosmic Physics National Conference, Rimini, October 26-28, 1994.

(**) The authors of this paper have agreed to not receive the proofs for correction.

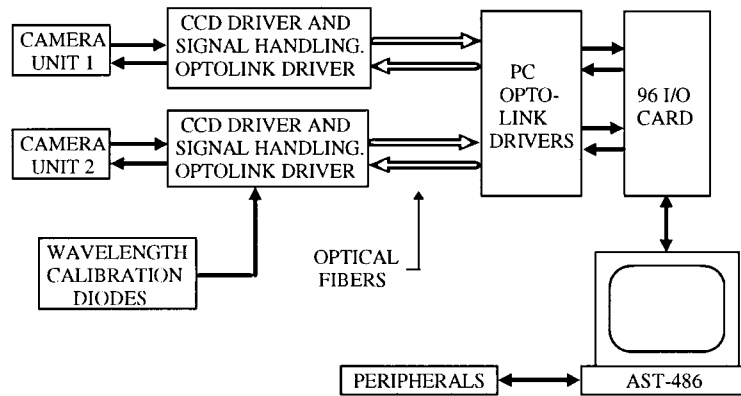

Fig. 1. – Block diagram of the whole system.

550 nm allowing spectroscopic “tomography” throughout the solar photosphere and chromosphere. The bandpass profile shows a noise in wavelength position corresponding to an uncertainty in Doppler velocity determination of 1 m/s r.m.s.

TABLE I. – *IMACS characteristics.*

CCD Thomson 31159A 512 × 512	
Pixel size	19 × 19 μm ²
Read-out time	10 μs/pixel
Frame read-out time	2.5 s
Storage time on HD	1.1 s
Frame acquisition rate	16 images/min
Uninterrupted acquisition time	4.3 h
CCD temperature	−40°C
Overall noise	37 e [−]
Gain calibration	8.7 e [−] /ADU
Dark current	40 e [−] /s
CCD TIJ 1024 × 1024	
Pixel size	18 × 18 μm ²
Read-out time	7 μs/pixel
Frame read-out time	8.4 s
Storage time on HD	4.6 s
Frame acquisition rate	4 images/min
Uninterrupted acquisition time	3.7 h
CCD temperature	−40°C
Overall noise	under test
Gain calibration	under test
Dark current	5 e [−] /s

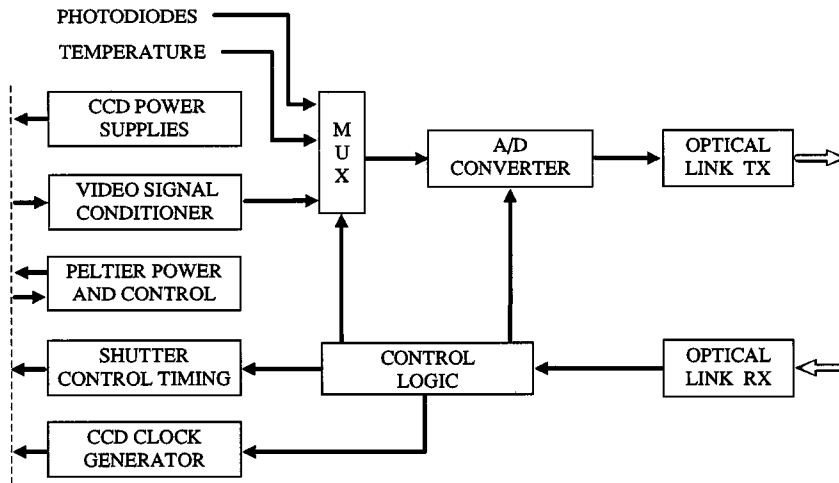

Fig. 2. – The signal conditioning unit.

2. – System description

The image acquisition is based on CCD cameras [4] using Thomson 31159A sensors, 512×512 pixels in size, cooled at about -40°C by a Peltier device and water circulation, enclosed in a vacuum tight aluminum container (TIJ devices 1024×1024 pixels are under test for the same cameras). The IMACS characteristics for the two systems are reported in table I. The block diagram of the system is shown in fig. 1. Two identical cameras and signal conditioning units are present in the system: the first one is dedicated to the detection of the spectral image, while the second one takes a white light image necessary to apply the de-stretching technique.

Two photodiodes are used to measure the intensity profile of a spectral line, provided by a cadmium lamp, passing through the Fabry-Perot interferometer in order to perform a wavelength calibration.

The physical layout of the telescope and thermal considerations required to separate the detection electronics, necessarily close to the focal plane of the telescope, from the acquisition, mass storage and data handling units, situated far from the telescope. This separation has been obtained by the transmission, over optical fiber, of the digitized video signals (from the detector to the computer) and of the command signals (in the opposite direction). The digital data are transmitted serially at 16 Mbit/s, requiring only two fibers for each camera. A specially designed interface connects the optolinks to the computer via an input-output card. The signal conditioning unit shown in fig. 2 receives the commands from the computer via the optolink and generates the shutter timing, the CCD read-out signals and the analog multiplexer and A/D converter control signals. The video signal, amplified and sampled [4] is converted into a 12-bit digital data; four additional bits are added for check purpose, thus forming a 16-bit word serially transmitted over the optical link.

The optolink to PC interface shown in fig. 3 is made of an optical receiver feeding a temporary buffer FIFO (First In First Out) memory; the FIFO is read by the PC via a parallel interface with hardware handshake signals and in software polling mode. The optical transmitter is directly interfaced with the PC parallel output lines.

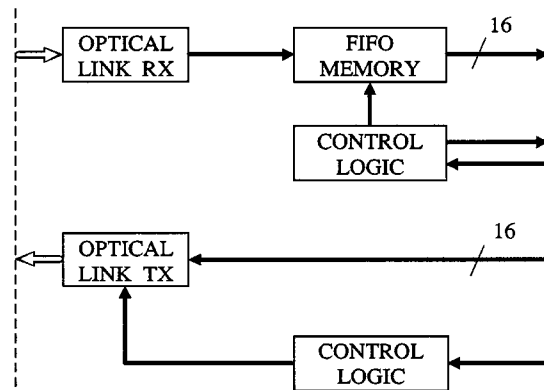

Fig. 3. – The optolink to PC interface.

The computer system shown in fig. 4 is composed of a 486/25 compatible PC with 8 MByte of RAM and a 200 MByte hard disk. A SCSI controller interfaces to the mass storage, composed of two 1.2 GByte hard disks for the real-time storage of the images and a 2.2 GByte cassette tape for data archiving. An I/O card with 96 programmable lines is dedicated to the interface with the two full duplex optical links.

3. – System performances

The ratio g between the number of photoelectrons collected on a pixel and the corresponding output voltage expressed in levels of the Analog-to-Digital converter (A/D Units or ADU) characterizes the behaviour of a CCD system.

The coefficient g is determined by applying the photon transfer curve technique described by Mackay [5] and by Jenescic *et al.* [6, 7]. The technique (referred to as Photon Transfer Technique) consists in acquiring “flat” images (*i.e.* images of a uniformly illuminated field) at different levels of illumination and computing their spatial mean and standard deviation after removing the offsets introduced by the electronics and by the dark current. The curve obtained by plotting on a logarithmic scale the r.m.s. deviation of the signal *vs.* the signal itself, both measured in ADU, presents two asymptotes of different

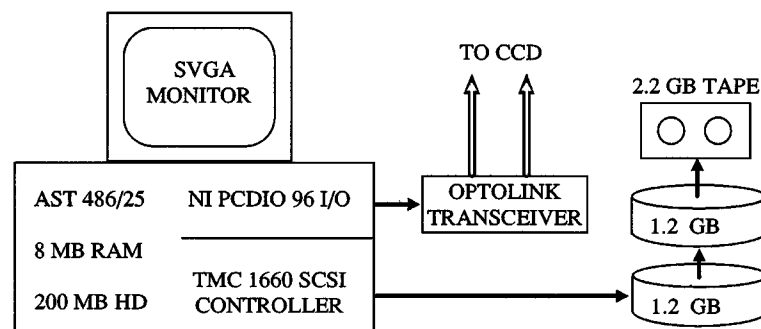

Fig. 4. – The computer system.

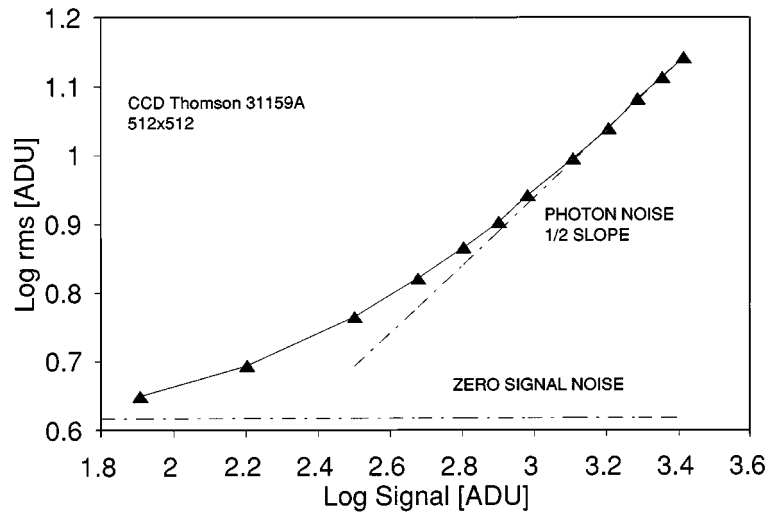

Fig. 5. – Photon transfer curve.

slopes (fig. 5).

The asymptote at high values shows that the signal tends to be dominated by the photon noise and has a slope equal to 1/2 (due to the statistical nature of photon emission). The intercept of this asymptote with the axis of abscissae gives the logarithm of the value of the coefficient g .

The other asymptote, parallel to the abscissae axis, shows that, at low signal level, the noise becomes essentially independent of the signal. The ordinate of the asymptote gives the value of the zero-signal noise. In the absence of signal, the noise consists of the read out noise, the CCD thermal noise and the noise due to the amplification chain. The

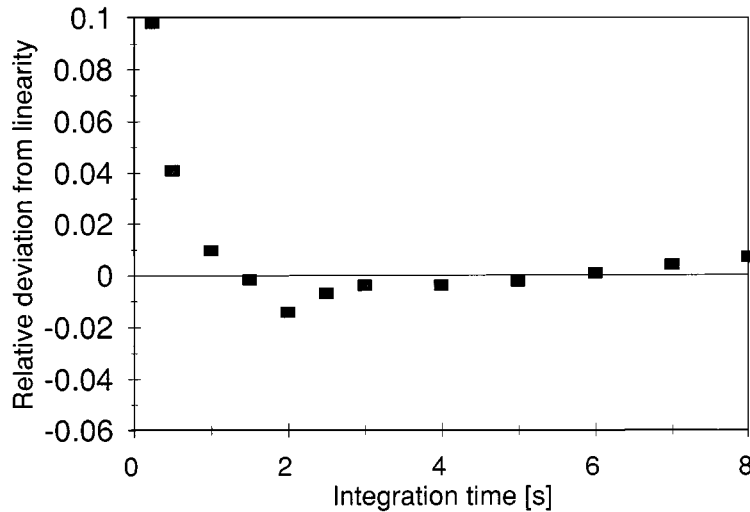

Fig. 6. – Linearity curve showing the relative deviations from the best-fit line, in A/D units, vs. exposure time, under a constant illumination.

thermal noise, at the working temperature of -40°C , is negligible with respect to the read out noise, while the amplifier chain noise is still smaller.

CCD image sensors are essentially linear devices, for which the output signal is directly proportional to the collected charge in a given interval of charge accumulated in the pixel well. The linearity is limited by secondary effects in the read-out capacity and electronic chain; typically these effects result in non-linearity values less than 1% in the range of utilization (fig. 6). Non-linearity may increase at very low collected charge and at a charge close to the maximum allowed.

4. – Scientific programs

Spectroscopic imaging at high space resolution (< 0.5 arcsec) of the solar photosphere and chromosphere with the IPM, together with simultaneous observations of the three components of the magnetic field allowed by the THEMIS spectrograph, will be a fundamental tool for the study of the local interactions between the plasma and the magnetic field and to get new insights into the long-standing problem of the solar dynamo [8, 9]. Among the scientific programs that can exploit the unique performances of the whole instrument, we mention the study of:

- the properties of the granulation and of the magnetic fluxtubes forming the photospheric network;
- the interaction between the oscillations and the magnetic field, both in the quiet network and in active regions;
- the evolution of velocity and magnetic field in young active regions, in connection with the emergence of new magnetic flux and with the development of solar flares.

Finally we must also remember the opportunities offered by coordinated campaigns of observations in connection with space experiments. First of all, starting with the summer of 1996, those on board of the SOHO Satellite, particularly those providing high spatial resolution images of the transition region between the chromosphere and the corona.

* * *

This work was financially supported by CNR-GIFCO and by MURST.

REFERENCES

- [1] RAYROLE J., MEIN P. and CAVALLINI F., *Solar Surface Magnetism*, edited by R. J. RUTTEN and C. J. SCHRIJVER (Kluwer, Dordrecht), 1994, p. 507.
- [2] BONACCINI D., CAVALLINI F., CEPPATELLI G. and RIGHINI A., *Astron. Astrophys.*, **217** (1989) 368.
- [3] CAVALLINI F., *Mem. Soc. Astron. Ital.*, **64** (1993) 764.
- [4] BERRILLI F., CANTARANO S., EGIDI A. and MAGAGNA A., *Nuovo Cimento C*, **15** (1992) 519.
- [5] MACKAY C. D., *Annu. Rev. Astron. Astrophys.*, **24** (1986) 255.
- [6] JENESIC J. R., ELLIOTT T., COLLINS S., BLOUKE M. M. and FREEMAN J., *Opt. Engin.*, **26** (1987) 692.
- [7] JENESIC J. R., KLAASEN K. and ELLIOTT T., *Opt. Engin.*, **26** (1987) 972.
- [8] CAVALLINI F., CEPPATELLI G., RIGHINI A., BERRILLI F., CACCIN B., CANTARANO S., EGIDI A., FRANCA P. and PIETROPAOLO E., *Nuovo Cimento C*, **15** (1992) 509.
- [9] BERRILLI F., CACCIN B., CANTARANO S., CAVALLINI F., CEPPATELLI G., EGIDI A., FRANCA P., PIETROPAOLO E. and RIGHINI A., *Mem. Soc. Astron. Ital.*, **64** (1993) 781.