

The possible detection of dark energy on earth using atom interferometry

M. L. PERL(*)

*SLAC National Accelerator Laboratory
2575 Sand Hill Road, Menlo Park, California, 94025, USA*

(ricevuto il 14 Settembre 2010; pubblicato online il 13 Gennaio 2011)

Summary. — This paper describes the concept and the beginning of an experimental investigation of whether it is possible to directly detect dark energy density on earth using atom interferometry. The concept is to null out the gravitational force using a double interferometer. This research provides a non-astronomical path for research on dark energy. The application of this method to other hypothetical weak forces and fields is also discussed. In the final section I discuss the advantages of carrying out a dark energy density search in a satellite in earth orbit where an even more sensitive search can be achieved.

PACS 95.36.+x – Dark energy.

1. – Table of contents

- 1) History of concept of using atom interferometry to investigate dark energy.
- 2) Conventional beliefs about the nature of dark energy.
- 3) Comparison of dark energy density with energy density of a weak electric field.
- 4) The terrestrial gravitational force field and a possible dark energy force.
- 5) Preliminary considerations on how well we can null out g .
- 6) Our assumptions about the properties of dark energy that make the experiment feasible.
- 7) Brief description of experimental search method.
- 8) Nature of sought signal.

(*) E-mail: martin@slac.stanford.edu

- 9) Other very weak forces and fields.
- 10) This experimental search method using an earth orbit satellite.

2. – Origin of paper

This paper is a summary of the talk I presented at the Les Rencontres de Physique de la Valle d’Aoste, Results and Perspectives in Particle Physics, March 6, 2010.

3. – History of concept of using atom interferometry to investigate dark energy

The majority of astronomers and physicists accept the reality of dark energy but also believe it can only be studied indirectly through observation of the structure and motions of galaxies. Astronomical investigation of dark energy are limited by their nature to:

- Measurement of the dark energy density, ρ_{DE} .
- Search for gross variations of ρ_{DE} in the visible universe.
- Elucidation of the change in ρ_{DE} in the past.
- There is no known way to investigate the intrinsic nature of dark energy using observational astronomy.

Several years ago [1] I began to search for non-astronomical ways to investigate the nature of dark energy and realized that there was a possibility, albeit experimentally speculative, to use atom interferometry [2]. Atom interferometry is a research technology whose practice is about three decades old [3].

I was then joined in this research area by Holger Mueller of the Physics Department, University of California at Berkeley and we continue to work together [2]. This present paper recapitulates that paper [2] in sects. **1-9** and discusses three important new aspects of this research in sects. **10-12**.

- The character of our signal is noiselike because of the motion of the earth through space, sect. **10**.
- The research method is applicable to searches for hypothetical very weak forces and fields, sect. **11**.
- There are substantial advantages to eventually carrying out these searches in a satellite in an earth orbit, sect. **12**.

We use MKS units rather than astronomical units to emphasize practical laboratory experimental designs and considerations. Recall

- Critical energy density = $\rho_{\text{crit}} = 9 \times 10^{-10} \text{ J/m}^3$.
- Dark energy density = $\rho_{DE} = 0.70 \times \rho_{\text{crit}} = 6.3 \times 10^{-10} \text{ J/m}^3$.
- $\hbar = 1.054 \times 10^{-34} \text{ Js}$.
- $G = 6.67 \times 10^{-11} \text{ m}^3 \text{ kg}^{-1} \text{ s}^{-2}$.

4. – Conventional beliefs about the nature and investigation of dark energy

Present conventional beliefs about dark energy density are that it is uniformly distributed in space and that its magnitude is given by $6.3 \times 10^{-10} \text{ J/m}^3$. The usual assumption is that every cubic meter of space contains the same dark energy density so that as the visible universe expands there is more total dark energy. I find it disquieting that most physicists and astronomers are content to live with this violation of the conservation of energy, it leads to my doubts that the community has basic understanding of dark energy and has encouraged me to go in this new research direction.

$\rho_{DE} = 6.3 \times 10^{-10} \text{ J/m}^3$ initially strikes one as a very small energy density but as shown in the next section we experiment with smaller electric field energy densities in the laboratory.

5. – Comparison of dark energy density with the energy density of a weak electric field

Consider a weak electric field $E = 1 \text{ volt/m}$. Using

$$(1) \quad \rho_{\text{electric field}} = \epsilon_0 E^2 / 2,$$

$$(2) \quad \rho_{\text{electric field}} = 4.4 \times 10^{-12} \text{ J/m}^3.$$

Hence the energy density of this electric field is 100 times smaller than the dark energy density, $\rho_{DE} = 6.3 \times 10^{-10} \text{ J/m}^3$, yet this weak electric field is easily detected and measured. Thus we work with fields whose energy densities are much less than ρ_{DE} . This realization first started me thinking about the possibility of direct detection of dark energy.

Of course, it is easy to sense and measure tiny electromagnetic fields; on the other hand there are obviously severe experimental problems in detecting dark energy density.

- Unlike an electric field in the laboratory, we cannot turn dark energy on and off.
- We do not know if there is a zero dark energy field to use as an experimental reference. In the fixed value, cosmological constant, explanation of dark energy, ρ_{DE} has the same value in all space.
- Even if the dark energy density should have a gradient, what force does it exert on a material object?

6. – The terrestrial gravitational force field and a possible dark energy force

In atom interferometry the phase change of atoms depends upon the integral of the potential difference between two separate trajectories of the atom in space. Of course at present we know nothing about whether or not dark energy exerts such a force. Indeed investigating this question is one of the purposes of our proposed experiment. In analogy we designate this force as g_{DE} in units of force per unit mass.

Comments on g and g_{DE} .

- 1) The gravitational force per unit mass on earth is $g = 9.8 \text{ m/s}^2$.

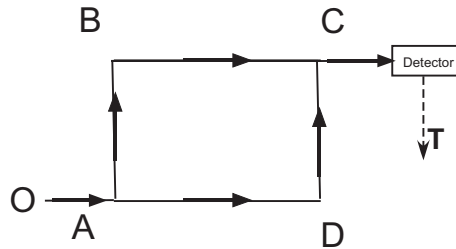

Fig. 1. – Diagram of an atom interferometer using the Mach-Zehnder concept.

- 2) Atom interferometry studies have reached a sensitivity of much better than $10^{-9}g$ in measurements of the gravitational acceleration [4] and found no anomaly. Even though a definite analysis for this has not been performed, it is probably safe to say that there is no evidence for g_{DE} at this level.
- 3) Therefore $g_{DE} \leq 10^{-8} \text{ m/s}^2$ using our assumptions about the properties of dark energy.

7. – Preliminary considerations on how well we can null out g

Based on preliminary considerations we believe we can null out g to a precision perhaps as small as 10^{-17} . This sets the smallest g_{DE} that we can investigate at 10^{-16} m/s^2 .

8. – Assumptions about the properties of dark energy that make the experiment feasible

We assume:

- A dark energy force, F_{DE} , exists other than the gravitational force equivalent of ρ_{DE} .
- F_{DE} is sufficiently local and ρ_{DE} is sufficiently non-uniform so that F_{DE} varies over a length of the order of centimeters to meters.
- F_{DE} acts on atoms leading to a potential energy V_{DE} .
- The ratio g_{DE}/g is large enough for g_{DE} to be detected in this experiment by nulling signals from g .

9. – Brief description of our experimental method

The search for F_{DE} requires the nulling of all the known forces that can change the atomic phase. The effects of electric and magnetic forces are nulled by shielding and by using atoms such as cesium in quantum states which are not sensitive to the linear Zeeman and Stark effects. The gravitational force is nulled by using two identical atom interferometers as described next.

Figure 1 is a schematic diagram of an atom interferometer using the Mach-Zehnder concept, the solid lines represent atom beams. An atom beam from source O is split at A so that each atom quantum mechanically follows the two paths ABC and ADC. At D

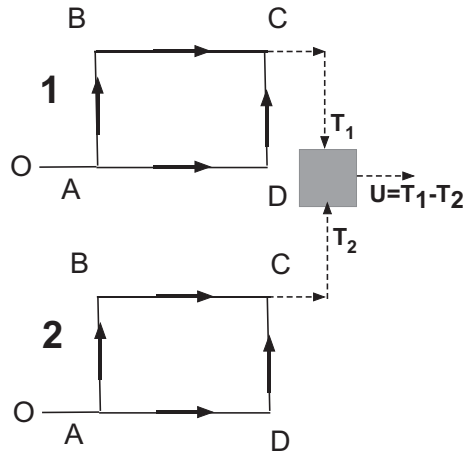

Fig. 2. – Diagram of the double atom interferometer.

the two states arrive with relative phases, ϕ_{ABC} and ϕ_{ADC} . The interference produces a signal T proportional to the phase difference $\phi_{ABC} - \phi_{ADC}$. T depends upon the potentials acting on the atoms in the space ABCD. The plane of the interferometer may be vertical or horizontal with respect to the earth's surface, our present preference is the vertical orientation.

Figure 2 shows the double apparatus schematically, two identical atom interferometers are used with the solid lines representing atom beams and the dashed lines representing signal flow. The apparatus is in the vertical orientation. Interferometers 1 and 2 produce signals T_1 and T_2 , each signal being dependent on the potentials acting on the atoms in the spaces ABCD. Considering just the earth's gravitational force \vec{g} , T is proportional to the change in gravitational potential between the upper path ABC and the lower path ADC, and thus proportional to the gravitational acceleration g .

$U = T_1 - T_2$ is given by the difference between the accelerations of free fall at the locations of the first and second interferometers. If we assume \vec{g} to be nearly constant at the earth's surface, $U = 0$ for contributions from \vec{g} , except for small corrections. Thus signals from the gravitational force are nulled by this interferometer design.

One realization of this design is a pair of fountain interferometers as described by Chung and his coworkers [4]. Even in a single interferometer, suppression of the signal due to g to the $10^{-10}g$ level has already been demonstrated by subtracting a Newtonian model of tidal variations caused by the Moon, the Sun, and the planets. Using the pair of interferometers described above, we expect to be able to cancel the effects of gravity by a factor of 10^{-17} .

10. – Nature of sought signal

Figure 3 is a schematic illustration of how inhomogeneous dark energy density could produce a non-zero signal U with a value dependent upon the degree of inhomogeneity, the force exerted by dark energy on atoms, and the configuration of the double interferometer.

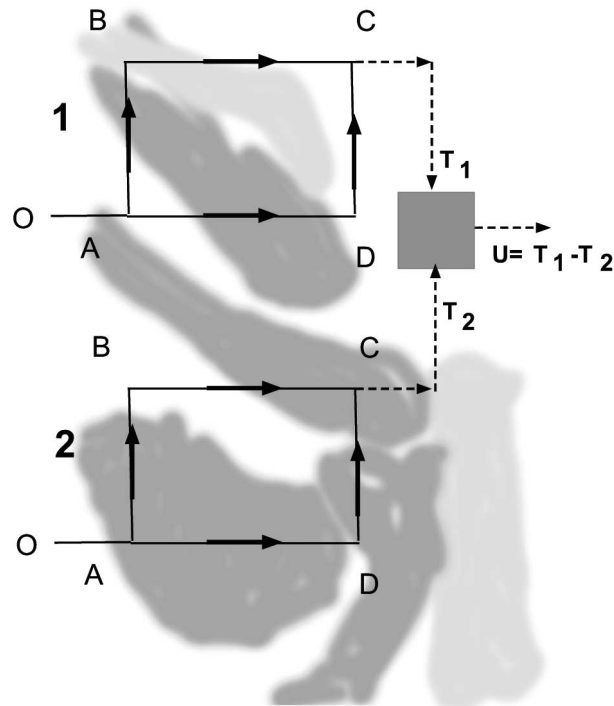

Fig. 3. – Illustration of how inhomogeneous dark energy density could produce a non-zero signal. The gray shapes represent the assumed inhomogeneity of the distribution of dark energy density.

In this experiment the interferometers are fixed to the earth. The earth is spinning and moving in the Galaxy and the Galaxy is moving in the CMB frame with a velocity about 400 km/s. Using present atom interferometer readout methods, U will be sampled at time intervals of the order of seconds to minutes. In this search dark energy density is assumed to be inhomogeneous, but of course we know nothing about what the velocity of the dark energy density might be. In any case, the dark energy clumps are not tied to the earth. Therefore the sought signal will average over many samplings of different dark energy densities and will *appear to be a noise signal*. This noise signal appearance has three consequences:

- If a noiselike signal is found from output of the double interferometer, we must show that it is not instrumental noise.
- If a noiselike signal is found, we do not know how to show that it is related to dark energy.
- As noted in the next section the absence of a non-instrumental noiselike signal puts an upper bound on some other kinds of hypothetical forces and fields that might pervade the universe.

11. – Other very weak forces and fields

My colleagues Holger Mueller and Ronald Adler have emphasized that this atom interferometry search is a general exploration of the possible existence of very weak forces, forces much weaker than gravity. Of course the criteria of inhomogeneity and an effect on matter must be met.

Incidentally, to the best of my understanding, this research method is irrelevant to the grand old problem of understanding the cosmological significance of total zero-point vacuum energy.

12. – This experimental search method using an earth orbit satellite

Stern *et al.* [5] and Ertmer and Rasael [6] have emphasized the substantially increased precision obtained by carrying out atom interferometry experiments in the microgravity environment of an earth orbit satellite. There is a second advantage using an earth orbit satellite for atom interferometry searches for dark energy and other very weak forces. The nulling of g is much easier.

* * *

I am deeply indebted to H. MUELLER and R. ADLER for their patience in educating me in subjects ranging from the design of a magnetic optical trap to the proper application of general relativity to dark energy. I am grateful to my friends in the SLAC National Accelerator Laboratory for lunch table discussions and insightful criticisms of this speculative research. I thank my partner in life, J. BEATTIE, for her willingness to accept my preoccupation with this research. This research is presently supported by Stanford University funds and by the author. The SLAC National Accelerator Laboratory is providing laboratory space and its continuing stimulating atmosphere.

REFERENCES

- [1] PERL M. L., *Int. J. Mod. Phys. A*, **24** (2009) 3426.
- [2] PERL M. L. and MUELLER H., arXiv:1001.4061.
- [3] There is a large literature on atom interferometer but no textbooks or monographs completely devoted to the subject. For practical introductions to laser cooling and atom interferometry I recommend: WIEMAN C., FLOWERS G. and GILBERT S., *Am. J. Phys.*, **63** (1995) 317; MELISH A. S. and WILSON A. C., *Am. J. Phys.*, **70** (2002) 965; FOOT C. J., *Cont. Phys.*, **36** (1991) 369; CARNAL O. and MLYNEK J., *Phys. Rev. Lett.*, **66** (1991) 2689; PETERS A. *et al.*, *Philos. Trans. R. Soc. London, Ser. A*, **355** (1997) 2223; DE ANGELIS M., *Meas. Sci. Technol.*, **20** (2009) 022001; CRONIN A. D. *et al.*, *Rev. Mod. Phys.*, **81** (2009) 1051.
- [4] CHUNG K.-Y., CHIOU S.-w., CHU S. and MUELLER H., *Phys. Rev. D*, **80** (2009) 016002.
- [5] STERN G. *et al.*, *Eur. Phys. J. D*, **53** (2009) 353.
- [6] ERTMER W. and RASAEEL E. M., *Nucl. Phys. B (Proc. Suppl.)*, **166** (2007) 307.