

## A Proton Recoil Telescope for the characterisation of the neutron beam at n\_TOF

A. MANNA<sup>(1)(2)</sup>, S. AMADUCCI<sup>(6)(7)</sup>, M. BARBAGALLO<sup>(3)(5)</sup>, N. COLONNA<sup>(5)</sup>,  
L. COSENTINO<sup>(6)</sup>, P. FINOCCHIARO<sup>(6)</sup>, S. LO MEO<sup>(9)(1)</sup>, C. MASSIMI<sup>(1)(2)</sup>,  
M. MASTROMARCO<sup>(3)</sup>, P. M. MILAZZO<sup>(10)</sup>, F. MINGRONE<sup>(3)</sup>,  
L. TASSAN-GOT<sup>(3)(8)(4)</sup>, G. VANNINI<sup>(1)(2)</sup> and A. VENTURA<sup>(1)</sup>  
on behalf of the n\_TOF COLLABORATION

<sup>(1)</sup> *Istituto Nazionale di Fisica Nucleare, Sezione di Bologna - Bologna, Italy*

<sup>(2)</sup> *Dipartimento di Fisica e Astronomia, Università di Bologna - Bologna, Italy*

<sup>(3)</sup> *European Organization for Nuclear Research (CERN) - Geneva, Switzerland*

<sup>(4)</sup> *Institut de Physique Nucléaire, CNRS-IN2P3, Univ. Paris-Sud, Université Paris-Saclay F-91406 Orsay Cedex, France*

<sup>(5)</sup> *Istituto Nazionale di Fisica Nucleare, Sezione di Bari - Bari, Italy*

<sup>(6)</sup> *INFN Laboratori Nazionali del Sud - Catania, Italy*

<sup>(7)</sup> *Dipartimento di Fisica e Astronomia, Università di Catania - Catania, Italy*

<sup>(8)</sup> *National Technical University of Athens - Athens, Greece*

<sup>(9)</sup> *Agenzia nazionale per le nuove tecnologie (ENEA) - Bologna, Italy*

<sup>(10)</sup> *Istituto Nazionale di Fisica Nucleare, Sezione di Trieste - Trieste, Italy*

received 5 February 2019

**Summary.** — The neutron induced fission cross section of  $^{235}\text{U}$  is extensively used as a reference for neutron fluence measurements in various applications. At intermediate energies, the  $^{235}\text{U}(\text{n},\text{f})$  cross section plays an important role also for fundamental nuclear physics. Despite its widespread use, no data exist on neutron-induced fission of  $^{235}\text{U}$  above 200 MeV. Hence, there is a clear and long-standing demand from the International Atomic Energy Agency (IAEA) to complement the experimental database from 20 MeV to 1 GeV. For this purpose at the neutron facility n\_TOF at CERN the measurement of  $^{235}\text{U}(\text{n},\text{f})$  cross section was planned in October 2018, taking advantage of the intense neutron beam with a wide energy spectrum available in the experimental area. The cross section measurement will be performed relative to the elastic neutron-proton scattering, a very well known reaction generally accepted as primary reference. A prototype of the Proton Recoil Telescope detector, that will be used to measure the incident neutron flux, has been built and tested at n\_TOF in 2017.

## 1. – Scientific motivation

The  $^{235}\text{U}(n,f)$  cross section is one of the most important standard cross sections at the thermal energy point and between 0.15 MeV and 200 MeV [1].  $^{235}\text{U}$  is used for the measurement of the neutron fluence for various applications, ranging from the investigation of the biological effectiveness of high-energy neutrons to the measurement of high-energy neutron cross-sections of relevance for accelerator-driven systems, and is used as a reference for fission cross section measurements. Above 200 MeV the  $^{235}\text{U}$  cross section plays an important role also for fundamental nuclear physics. In fact at high excitation energy fission may be hindered with respect to particle emission due to its longer time-scale.

Despite its importance in the energy range between 20 MeV and 200 MeV, the neutron-induced fission cross section of  $^{235}\text{U}$  is based on two measurements only [2, 3], and there are no experimental data above 200 MeV. Moreover the evaluations by JENDL/HE [4] and the recent ones by the International Atomic Energy Agency (IAEA) [5], as well as the simulations [6], based on the intranuclear cascade model INCL++ [7] coupled to the deexcitation model GEMINI++ [8], outline the inconsistency of the models (see figure 1) and the need for new experimental measurements.

For this reason the IAEA requires new fission cross section measurements to be performed relative to n-p scattering, that is the primary reference [5].

## 2. – The neutron Time Of Flight facility at CERN

The n.TOF facility is a spallation neutron source operating at CERN (Geneva, Switzerland) since 2001 and is composed of two experimental areas [9, 10]. The n.TOF beam features a high energy resolution and a high neutron flux. The first characteristic is achieved using the Time of Flight (ToF) technique with a long flight path. The second obtained from spallation reactions induced by a 20 GeV/c momentum proton beam impinging on an 1.3 ton lead target. The proton beam is accelerated by the Proton Synchrotron (PS) which is capable of generating a pulse of  $7 \times 10^{12}$  protons, producing  $2 \times$

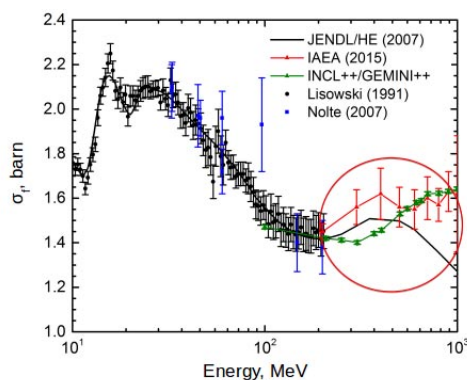

Fig. 1: The  $^{235}\text{U}(n,f)$  cross section from the JENDL/HE [4] and IAEA [5] evaluations, the experimental data [2, 3] measured relative to the n-p cross section and a new theoretical calculation [6].

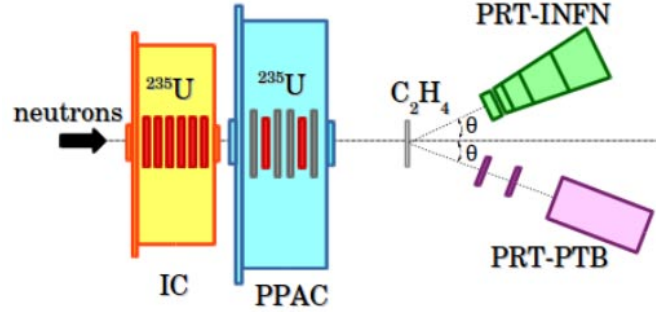

Fig. 2: Experimental setup of the test: two fission detectors and the Proton Recoil Telescopes pointing to a  $C_2H_4$  sample.

$10^{15}$  neutrons per bunch. A 1 cm water layer cools the target and, together with a layer of 4 cm of borated water, moderates the initially fast neutrons. The resulting energy spectrum covers about eleven orders of magnitude and ranges from thermal region up to 1 GeV.

### 3. – Experimental setup

During Autumn 2017 a test was performed to optimise the final setup for the  $^{235}U(n,f)$  cross section measurement of October 2018. The experimental setup of the test is shown in figure 2. The  $^{235}U$  fission fragment are detected using two detectors: a parallel plate avalanche counter (PPAC) and a parallel plate ionization chamber (IC). The PPAC, operating at low gas pressure, is well suited for the measurement of fission cross sections at neutron energies of several hundreds MeV. Its fragment-detection efficiency should be evaluated carefully, because it detects only fission fragments emitted in a cone with an opening angle of about  $60^\circ$ . In contrast, the fragment-detection efficiency of the IC is about 0.97 for  $300 \mu g/cm^2$  thick samples in the energy region below 200 MeV. Therefore, it will be used to study and eventually calibrate the PPAC fragment-detection efficiency in the energy range below 100 MeV.

The number of neutrons impinging on the  $^{235}U$  samples will be deduced by detecting recoil protons emitted from Polyethylene ( $C_2H_4$ ) samples. A Proton Recoil Telescope (PRT) will be used to measure and discriminate recoiling protons from other charged particles coming from the target. Events produced by light charged particles other than protons can be identified and discarded by measuring the differential energy loss in the transmission detectors and the remaining kinetic energy in the stop detector ( $\Delta E$ -E method). With the multiple coincidences between different telescope layers it is possible to identify the spurious events, produced by stray particles not coming directly from the radiator target or by scattered neutrons. Using the  $\Delta E$ -E method it is possible to separate the proton events from the background events and to measure the neutron flux.

Two different PRTs were tested at n\_TOF, one realized by INFN, and the other by Physikalisch-Technische Bundesanstalt (PTB). The PRT by INFN is composed by two silicon detectors,  $300 \mu m$  thick, and an array of 4 plastic scintillators, 5 mm, 30

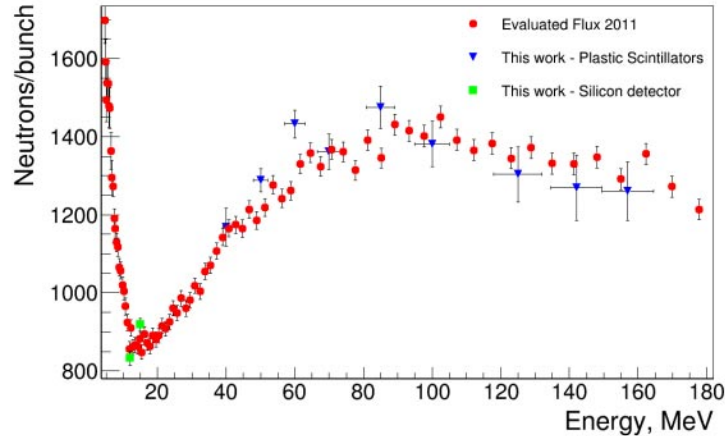

Fig. 3: The evaluated flux defined during the n\_TOF commissioning (red dots) and the extracted neutron flux (blue and green dots) using a PRT-INFN detector.

mm, 60 mm and 60 mm thick, respectively. The data collected in 2017, during the test experiment, have been used to extract the neutron flux. It is shown in figure 3 together with the flux defined during the commissioning of the facility.

#### 4. – Conclusion

The  $^{235}\text{U}(n,f)$  cross section is going to be measured in October 2018 at the CERN n\_TOF facility in a wide energy range from 20 MeV up to 1 GeV. This measurement, in particular in the region above 200 MeV where no experimental data are available, is of primary importance for many applications in nuclear physics. The neutron flux will be measured simultaneously with the fission cross section using the n-p reaction and dedicated proton recoil telescopes.

After a test performed in Autumn 2017 the final experimental setup has been designed: two fission detectors and three Proton Recoil Telescopes to cover all the energy range of interest and minimize systematic effects.

#### REFERENCES

- [1] CARLSON A.D. *et al.*, *Nuclear Data Sheets*, **110** (2009) 3215.
- [2] CARLSON A.D. *et al.*, in *Proc. of the Int. Conf. on Nuclear Data for Science and Technology, Juelich (Germany) 13-17 May 1991* edited by QAI S.M. (SPRINGER) (1992) 518.
- [3] NOLTE R. *et al.*, *Nuclear Science and Engineering*, **156** (2007) 197.
- [4] WATANABE Y. *et al.*, *Journal of the Korean Physical Society*, **59** (2011) 1040.
- [5] INTERNATIONAL NUCLEAR DATA COMMITTEE, *INDC (NDS)*, **0681** (2014) 16.
- [6] LO MEO S. *et al.*, *Nucl. Phys. A*, **933** (2015) 43.
- [7] BOUDARD A. *et al.*, *Phys. Rev. C*, **87** (2013) 014606.
- [8] MANCUSI D. *et al.*, *Phys. Rev. C*, **82** (2010) 044610.
- [9] GUERRERO C. *et al.*, *Eur. Phys. J A*, **49** (2013) 27.
- [10] WEISS C. *et al.*, *NIM A*, **799** (2015) 90.